

Surname	Centre Number	Candidate Number
Other Names		0



GCSE – NEW

3310U60-1



A16-3310U60-1

**MATHEMATICS – NUMERACY
UNIT 2: CALCULATOR-ALLOWED
HIGHER TIER**

FRIDAY, 4 NOVEMBER 2016 – MORNING

1 hour 45 minutes

ADDITIONAL MATERIALS

A calculator will be required for this paper.
A ruler, a protractor and a pair of compasses may be required.

INSTRUCTIONS TO CANDIDATES

Use black ink or black ball-point pen. Do not use gel pen or correction fluid.
You may use a pencil for graphs and diagrams only.
Write your name, centre number and candidate number in the spaces at the top of this page.
Answer **all** the questions in the spaces provided.
If you run out of space, use the continuation page at the back of the booklet, taking care to number the question(s) correctly.
Take π as 3.14 or use the π button on your calculator.

INFORMATION FOR CANDIDATES

You should give details of your method of solution when appropriate.
Unless stated, diagrams are not drawn to scale.
Scale drawing solutions will not be acceptable where you are asked to calculate.
The number of marks is given in brackets at the end of each question or part-question.
In question 4(a), the assessment will take into account the quality of your linguistic and mathematical organisation, communication and accuracy in writing.

For Examiner's use only		
Question	Maximum Mark	Mark Awarded
1.	3	
2.	3	
3.	6	
4.	16	
5.	12	
6.	7	
7.	4	
8.	10	
9.	8	
10.	11	
Total	80	



NOV163310U60101

Formula List - Higher Tier

Area of trapezium = $\frac{1}{2}(a + b)h$

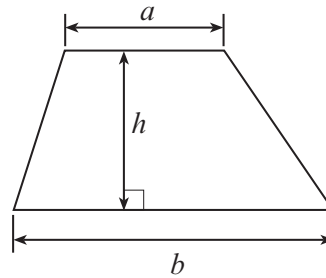

Volume of prism = area of cross-section \times length

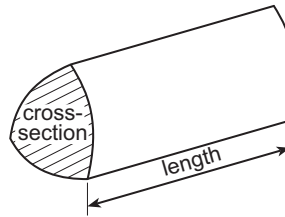

Volume of sphere = $\frac{4}{3}\pi r^3$

Surface area of sphere = $4\pi r^2$

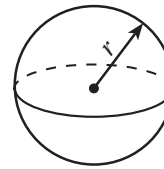

Volume of cone = $\frac{1}{3}\pi r^2 h$

Curved surface area of cone = $\pi r l$

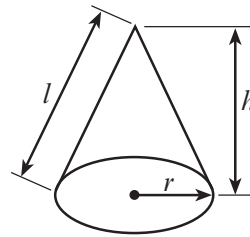

In any triangle ABC

Sine rule $\frac{a}{\sin A} = \frac{b}{\sin B} = \frac{c}{\sin C}$

Cosine rule $a^2 = b^2 + c^2 - 2bc \cos A$

Area of triangle = $\frac{1}{2} ab \sin C$

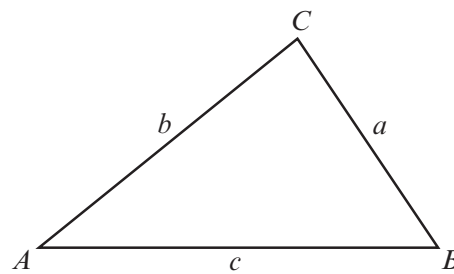

The Quadratic Equation

The solutions of $ax^2 + bx + c = 0$ where $a \neq 0$ are given by $x = \frac{-b \pm \sqrt{(b^2 - 4ac)}}{2a}$

Annual Equivalent Rate (AER)

AER, as a decimal, is calculated using the formula $\left(1 + \frac{i}{n}\right)^n - 1$, where i is the nominal interest rate per annum as a decimal and n is the number of compounding periods per annum.



1. (a) The Headteacher of Ysgol Bro Gwyn investigates building a new bike shed.

Bike sheds are built on a rectangular base of width x metres and length y metres.

The Headteacher is given a formula for working out the number of bikes, b , that can be stored in a bike shed that has a base of width x metres and length y metres.

He is told the formula only works when

- x and y are whole numbers
- x is greater than 3
- y is greater than 5

The formula is as follows:

$$b = \frac{6xy}{5}$$

According to the details the Headteacher has been given, what is the formula for calculating the length, y metres, of a bike shed x metres wide that can hold b bikes?

Circle your answer.

[1]

$$y = \frac{b-5}{6x}$$

$$x = \frac{6b}{5y}$$

$$y = \frac{b+5}{6x}$$

$$y = \frac{5b}{6x}$$

$$y = \frac{6x}{5b}$$

.....

.....

.....



- (b) The Headteacher decides to place signs around the school site to stop pupils using their bikes on grassed areas.

He introduces a new sign to pupils in the school newsletter.
The size of the sign in the newsletter is shown below.

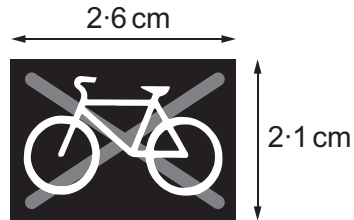

Diagram not drawn to scale

A mathematically similar new sign is placed near the side of the playing field.



Diagram not drawn to scale

It is 33.6 cm high.
How wide is this sign?

[2]

.....

.....

.....

.....

.....

.....

Width is cm



2. The price of softwood changes each year.
The price has increased by 6% per annum for each of the last **5 years**.
Before this, the price had decreased by 2% per annum.
Seven years ago the price of softwood was £34 per m³.

Calculate the current price of softwood.

[3]

.....

.....

.....

.....

.....

.....

.....

.....

.....

.....

.....

.....

.....

.....

.....

.....

.....

.....

.....

.....

.....

.....

.....

.....

.....

.....

.....

Current price of softwood is £ per m³

3310U601
05



3. The wire window guard shown below is to be made.

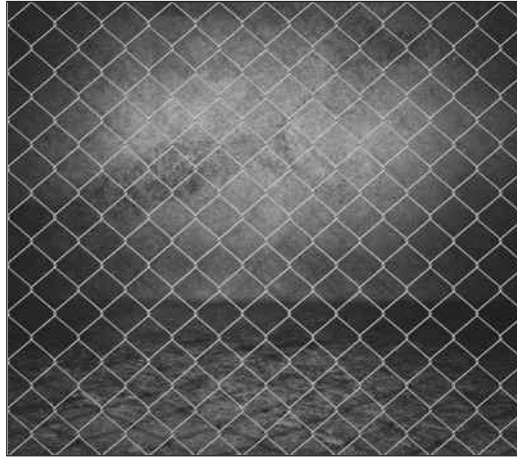

Diagram not drawn to scale

The length of the sides of each small wire square shown is 3.3 cm.

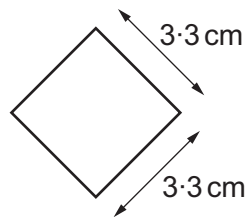

Diagram not drawn to scale

Linos considers the length of the diagonal of each small square.

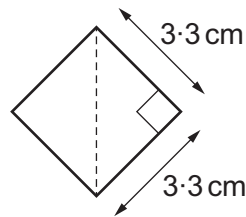

Diagram not drawn to scale

She says,

The height of the window guard is equal to 9.5 diagonals of the square.
The width of the window guard is equal to 11 diagonals of the square.



(a) Calculate the length of the diagonal of a small square.
Give your answer correct to 1 decimal place.

[3]

.....

.....

.....

.....

.....

.....

.....

.....

.....

.....

.....

.....

.....

.....

.....

.....

.....

.....

.....

.....

.....

.....

.....

(b) Calculate the area of the **window guard**.
You must show all your working.

[3]

.....

.....

.....

.....

.....

.....

.....

.....

.....

.....

.....

.....

.....

.....

.....

.....

.....

.....

.....

.....

.....

.....

.....

.....

3310U601
07



4. Gwenda enjoys road running.

(a) *In this part of the question, you will be assessed on the quality of your organisation, communication and accuracy in writing.*

She keeps a record of her run each day this week.

Day	Sun	Mon	Tues	Wed	Thurs	Fri	Sat
Distance	4.6 km	5.4 km	2.2 km	6.2 km	7.2 km	2.2 km	3.4 km
Time	26 mins	31 mins	12 mins	35 mins	40 mins	14 mins	22 mins

Last week, her average speed for the week was 9.6 kilometres per hour.
 Calculate Gwenda's percentage improvement in her average speed from last week to this week.
 You must show all your working. [6 + 2 OCW]

.....

.....

.....

.....

.....

.....

.....

.....

.....

.....

.....

.....

.....

.....

.....

.....

.....

.....

.....

.....

.....

.....

Percentage improvement is %



(b) The diagram shows the cross-section of one part of her run.

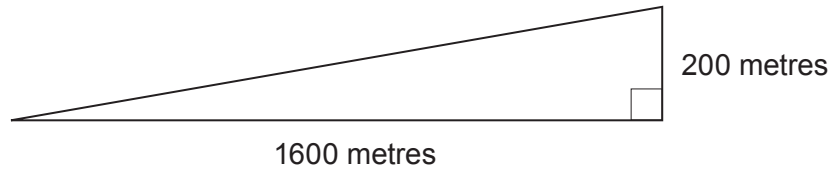

Diagram not drawn to scale

Calculate the angle of elevation of the road.

[3]

.....

.....

.....

(c)

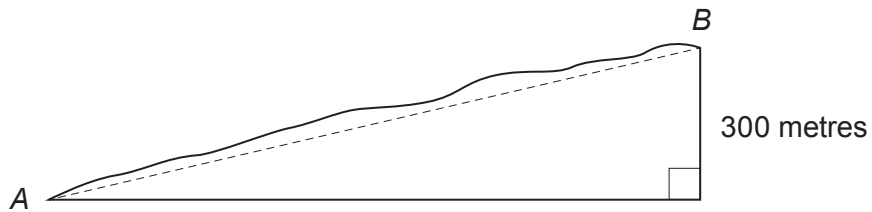

Diagram not drawn to scale

Gwenda runs on another section of uneven road from *A* to *B*.
 The rise in this section of the road is 300 metres.
 The angle of elevation of *B* from *A* is 10° .

(i) Calculate an estimate of how far Gwenda has run.
 State any assumption you have made.

[4]

.....

.....

.....

.....

Assumption:

.....

(ii) What is the impact of your assumption on your answer?

[1]

.....

.....

3310U601
09



5. Rhodri has carried out an experiment to measure the diameters of 20 spherical dust particles, in microns.

Here are his results.

Diameter, d (microns)	Frequency
$1 \leq d < 2$	2
$2 \leq d < 4$	6
$4 \leq d < 5$	8
$5 \leq d < 9$	4

- (a) (i) Calculate an estimate of the mean diameter of a dust particle. [4]

.....

.....

.....

.....

.....

.....

- (ii) Rhodri measures the diameters of another 25 dust particles.

Rhodri is told,

'The ratio of dust particles with diameters less than 4 microns to those with diameters greater than or equal to 4 microns is 7 : 8.'

He finds this fact is true when he considers all 45 dust particles.

How many of the extra 25 dust particles have a diameter of less than 4 microns?
You must show your working. [3]

.....

.....

.....

.....

.....

.....



6. Porth Ifan Hospital has made some changes to improve patient care. A survey is to be used to find out the views of the hospital staff.

(a) The table shows the total number of staff in each job type.

Job type	Doctor	Nurse	Management	Clerical
Number of staff	120	320	56	144

The survey is to be given to a sample of 75 staff.

Use a stratified sampling method to calculate the number of staff from each job type that should be asked to complete the survey.
You must show your working. [4]

.....

.....

.....

.....

.....

.....

.....

.....

.....

.....

.....

.....

.....

.....

.....

.....

.....

.....

.....

Job type	Doctor	Nurse	Management	Clerical
Number in sample				



7. Here is some information from a 2014 geographical journal:

- Population of the UK: 6.5×10^7 , correct to the nearest 1 000 000
- Area of the UK: 244 000 km², correct to the nearest 1000 km²

Using these figures, calculate the greatest possible value for the population density of the UK, in population per km². [4]

.....

.....

.....

.....

.....

.....

.....

.....

.....

.....

.....



8. A confectionary company is designing a new chocolate-covered biscuit in the shape of a square-based pyramid. The centre of the square base is labelled O . Each biscuit will have base sides of length 3.4 cm, and a vertical height of 2.1 cm.

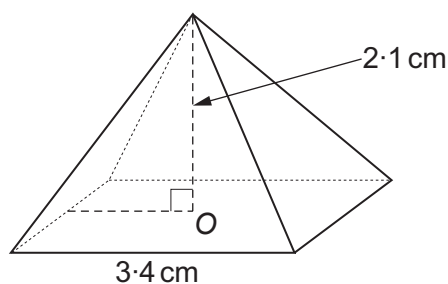

Diagram not drawn to scale

- (a) Calculate the angle that one of the triangular faces makes with the base of the pyramid. [4]

.....

.....

.....

.....

.....

- (b) The company knows that it costs $0.08p$ per cm^2 to apply a chocolate covering. Calculate the cost of applying a chocolate covering to all 5 faces of a biscuit. [6]

.....

.....

.....

.....

.....

.....

.....

.....

.....

.....



9. A metal round-headed nail can be thought of as a cone sitting on top of a cylinder, which sits on top of a hemisphere.
 A company produces round-headed nails of different sizes, but made of the same metal.
 Each nail has the following dimensions:
- height of cone = $9r$,
 - height of cylinder = $15r$,
 - radius of the hemisphere = $12r$,
- where r is the radius of the cylinder and the base radius of the cone.

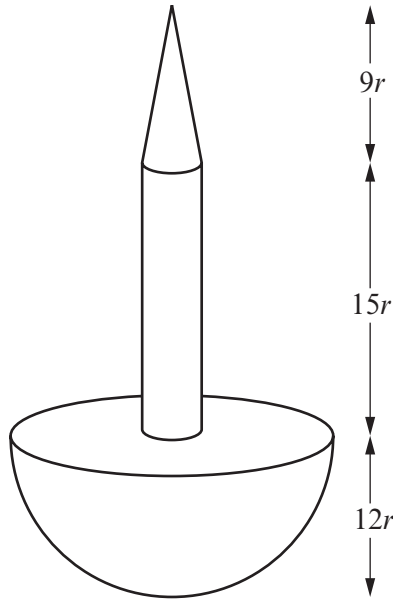

Diagram not drawn to scale

A metal cuboid of volume $18\,000\text{ mm}^3$ is melted down, and re-cast to form round-headed nails of size A, where $r = 0.4\text{ mm}$.

- (a) Calculate the greatest number of round-headed nails of size A that can be produced. [6]

.....

.....

.....

.....

.....

.....

.....

.....

.....

.....



(b) Circle either TRUE or FALSE for each statement given below.

[2]

STATEMENT		
A nail double the height of a size A nail will have a total height of 28.8 mm.	TRUE	FALSE
A nail double the height of a size A nail will be 8 times the weight of a size A nail.	TRUE	FALSE
A nail 3 times the height of a size A nail will have a total surface area 6 times that of a size A nail.	TRUE	FALSE
When $r = 0.8$ mm, the number of nails that could be produced from the same metal cuboid will be double the number of size A nails.	TRUE	FALSE



BLANK PAGE

**PLEASE DO NOT WRITE
ON THIS PAGE**



10. Huw wants to open a savings account.
Here are the details of savings accounts advertised by two local Welsh banks.

Banc Padarn

Nominal interest rate of 1.98%
per annum

Interest paid monthly

Banc Teilo

AER 1.99%

(a) (i) What is 1.98% as a decimal?
Circle your answer. [1]

- 0.0198 0.198 1.098 1.98 98.0

(ii) Which of these two banks should Huw choose in order to gain the most interest per annum?
You must show your working. [4]

.....

.....

.....

.....

.....

.....

.....

.....

.....

.....

.....

.....



(b) Interest earned from savings is taxable, according to the table below.

Tax rates for savings	
Basic rate taxpayer	20% on annual interest earned above £1000
Higher rate taxpayer	40% on annual interest earned above £500

Matthew is a higher rate taxpayer.
 Therefore, any savings interest he earns over £500 within a year is taxed at 40%.

On 1st May 2016, he invested £150 000 in a savings account that pays interest at a rate of 1.98% **per annum**.

(i) What is this interest rate **per month**, written as a decimal?
 Circle your answer. [1]

0.0033 0.00495 0.00165 0.0099 0.0066

Savings interest is added at the end of every month.

(ii) Calculate the date when the interest that Matthew earned went above his annual tax-free limit, and the amount of tax he would have to pay on this interest if he had closed the account on this date. [5]

.....

.....

.....

.....

.....

.....

.....

.....

.....

.....

.....

.....

.....

.....

.....

.....

.....

.....

.....

.....



.....

.....

.....

.....

.....

.....

.....

.....

.....

.....

Date Tax Matthew would have to pay

END OF PAPER



BLANK PAGE

**PLEASE DO NOT WRITE
ON THIS PAGE**



BLANK PAGE

**PLEASE DO NOT WRITE
ON THIS PAGE**

